

Spherical Roller Bearing

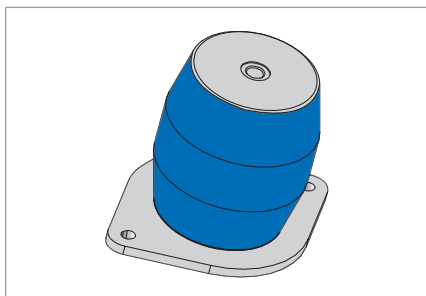

Fig. 1 Spherical Roller Bearing

Product description

Spherical roller bearings are ideal for their vertical loading and insulation against low-amplitude vibrations.

Product advantages

- Parallel fastening surfaces
- Installation with standard screws
- Prepared for heat dissipation
- Low proportion of metal
- RoHS-compliant.

Application

Masses that experience or themselves cause minor vibration amplitudes according to deflection can be mounted on spherical roller bearings. This makes this mount configuration suitable for selected engines, compressors, units, mounting equipment and also heavy duty switch cabinets, control systems, stationary control panels, measurement equipment.

Material

Standard material	Hardness
Natural rubber NR 11	45, 55, 65 Shore A

Operating conditions

Axial forces	9000 N ... 20000 N
Max. temperature	60 °C, transient +80 °C
Min. temperature	-45 °C

Spherical roller bearings have different stiffness in axial and radial direction. In the axial direction the stiffness is many times that of the radial direction.

The primary load direction is recommended to be in the longitudinal axis and central to the installation area.

Design notes

A key feature of the spherical roller bearings is the generally cylindrical to convex shape with central through-bore in the elastomer body. There is a metal plate with a central thread on one side on the front side, which is vulcanised to the elastomer body. On the opposite front side

there are several nuts vulcanised into the elastomer. The cylindrical to convex shape should be taken into account in the design of the consoles. This mount should only be used with axial preloading. Note that only small radial deflections are permitted.

Fitting & installation

- Rubber mounts are designed to be fitted vertically by means of threaded fasteners
- A sufficient radial spacing to the console components is required
- The installation areas must be free of fluids. There must be no metal shavings or sharp edges in the vicinity of the installation areas
- It is beneficial to ventilate the central bore in the elastomer body
- Radial or angular offset of the fastening areas caused by installation should be prevented
- Uniform screw tightness is required.

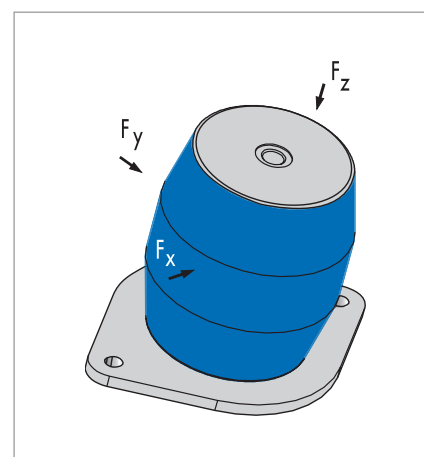

Fig. 2 Primary load direction

Article list

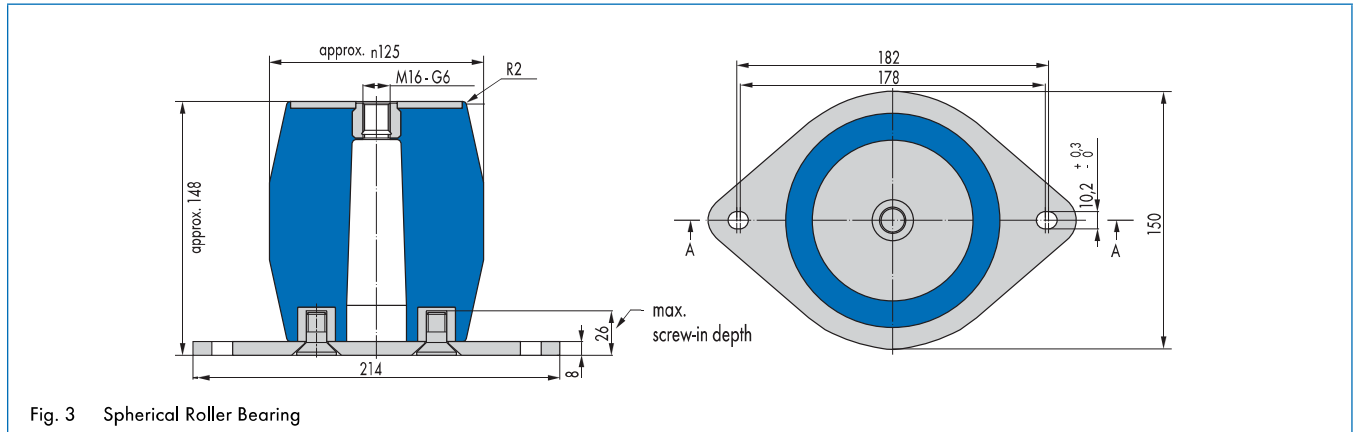

Fig. 3 Spherical Roller Bearing

Nominal maxima			Dimensions										Product No.	Material	with base plate	Article No.		
Axial pressure			D	d	H	ØT	P	ØC	ØW	L	G	E						
F _{z max}	s _{z max}	c _{z max}	[mm]	[mm]	[mm]	[mm]	[mm]			[mm]	[mm]	[mm]						
[N]	[mm]	[N/mm]																
9000	50	180	125	35	140	70	18	M16	M12	178 ... 182	150	10,2	3918 756	45 NR 11	mounted	49040133	○	
13800	50	280	125	35	140	70	18	M16	M12	178 ... 182	150	10,2	3918 756	55 NR 11	mounted	49040134	○	
20000	50	400	125	35	140	70	18	M16	M12	178 ... 182	150	10,2	3918 756	65 NR 11	mounted	49040135	○	
9000	50	180	125	35	140	70	18	M16	M12	-	-	-	3918 756	45 NR 11	without	49040061	○	
13800	50	280	125	35	140	70	18	M16	M12	-	-	-	3918 756	55 NR 11	without	49002648	○	
20000	50	400	125	35	140	70	18	M16	M12	-	-	-	3918 756	65 NR 11	without	49040132	○	

● Available from stock ○ On request: Tool is available, delivery at short notice